

TV DRAGO AX

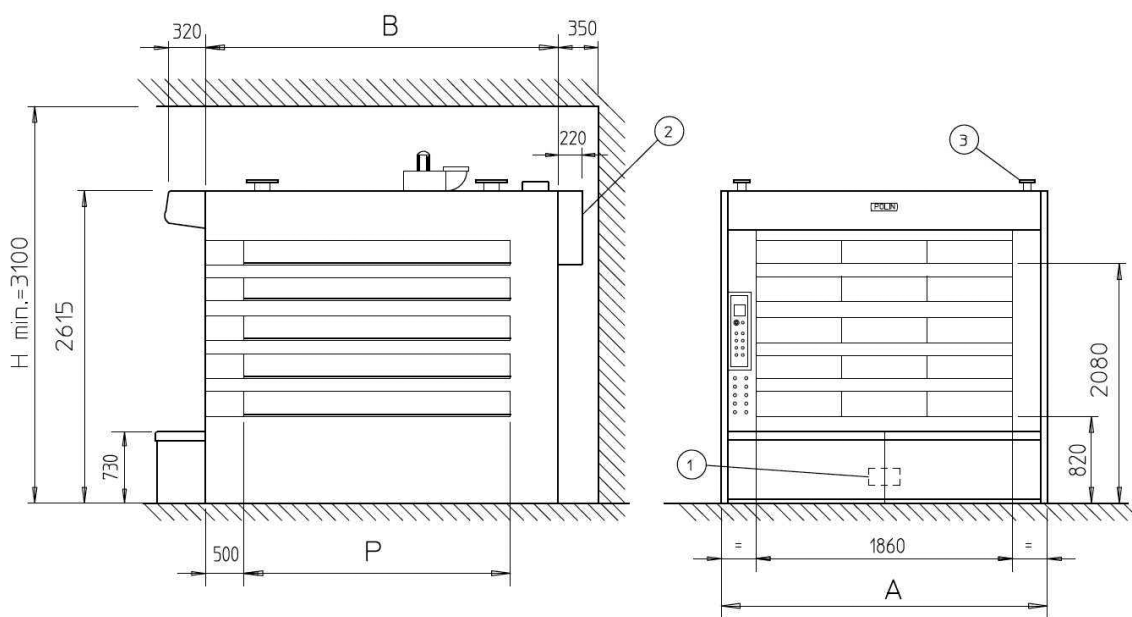

- Deck useful height 22 cm
- Presetting for automatic loading device installation
- Steamer for each deck on right side
- Deck ready for installation of supplementary steam generator
- Steam generators control by electrovalve with timer
- Hood with double speed exhaust fan
- Deck decompression discharge valve in the mouth
- Motorised chimney shutter
- Baking plates in "armored concrete"
- Safety thermostat
- Doors with low emission dismountable glass
- Automatic start
- Baking timer

Power inlet	400/3N~/50
Water inlet	Diameter 1/2" GAS
Steamer drain	Diameter 1" GAS
Steam exhaust output	Diameter 250 mm
Fume exhaust pipe	Diameter 200÷250 mm



	Chambers	Chambers dimensions		Overall dimension		Installed power		Minimum door width	Weight
		Height	Length	Width	Length	Thermic	Electrical		
	n°	mm	mm	mm	P mm	kcal/h	kW	mm	kg
15,8/186x170-5	5	220	1700	2525	2575	90.000	1,1	650x2200	8900
20,0/186x214-5	5	220	2140	2525	3015	115.000	1,1	650x2200	10700
24,0/186x258-5	5	220	2580	2525	3455	125.000	1,1	650x2200	12500